

Patterns and the Molding of Cast Iron Banks

Supplement No. 8: Melting and Pouring the Iron*

Fritz Kokesh

A. INTRODUCTION

The article "Patterns and the Molding of Cast Iron Still Banks"¹ touched on melting and pouring the iron. This supplement provides details about the equipment used and its operation. Topics include the structure and operation of the cupola used to melt the iron and the ladles used to pour it. A Glossary and photos of melting and pouring operations are included.

I am fortunate to be able to illustrate many points with photos taken at the Williamsport Foundry in Williamsport, Pennsylvania, which is a third-generation business now owned by Jeep, Bud, and Frank Doebler. There I was able to observe operation of the Whiting cupola that was installed in 1930 and has been used ever since, and I witnessed the skill and strength of the foundrymen working there.

B. CUPOLA STRUCTURE AND PRINCIPLE OF OPERATION

The cupola is simple both in construction and in its principle of operation. Basically, it is a vertical cylinder that is both the furnace in which fuel is burned in a forced draft and the vessel within which iron is melted. The key components of a Whiting standard cupola are shown in Illustrations 1 and 2. Illustration 3 has dimensions for a Whiting No. 2 1/2 cupola like that at the Williamsport Foundry.

The exterior of the cupola is formed of 1/8" to 1/4" thick boilerplate² and the interior is a "refractory" lining of "fire brick" coated with "daub." (These and other terms are explained in the Glossary.) About one foot above the bottom doors of the cupola there are one or two rows of openings called "tuyeres." The tuyeres are enclosed in the "windbox," an airtight chamber formed by a second concentric cylinder of boilerplate. The windbox distributes air from a blower to the tuyeres and creates a forced draft or "blast" within the cupola. Opposite each tuyere is an opening in the windbox equipped with a door that can be opened to admit air when the blower is not running, or through which a tapping chisel can be inserted to loosen slag that is blocking a tuyere. A "peep hole" in the tuyere door allows the cupola operator to look into the cupola to monitor the fire and the flow of iron down through the "coke."

The cupola is loaded with coke, iron, and "flux" through the charging doors accessed from the charging platform one level above the foundry floor. With the air blast, the fire becomes hot enough³ to melt the iron (its melting point is about 2,200 degrees Fahrenheit), which runs down through the coke bed and collects at the bottom of the cupola. Impurities called "slag" also liquefy but float on the iron, and as the level of molten materials rise, flow out through the "slag hole" (also called the "slag spout"). When sufficient molten iron has accumulated, the cupola is tapped and the iron runs out the "tap hole" to a ladle, from which it is moved to the molds.

* Copyright © 2005 Fritz Kokesh, Portland, Oregon. All rights reserved.

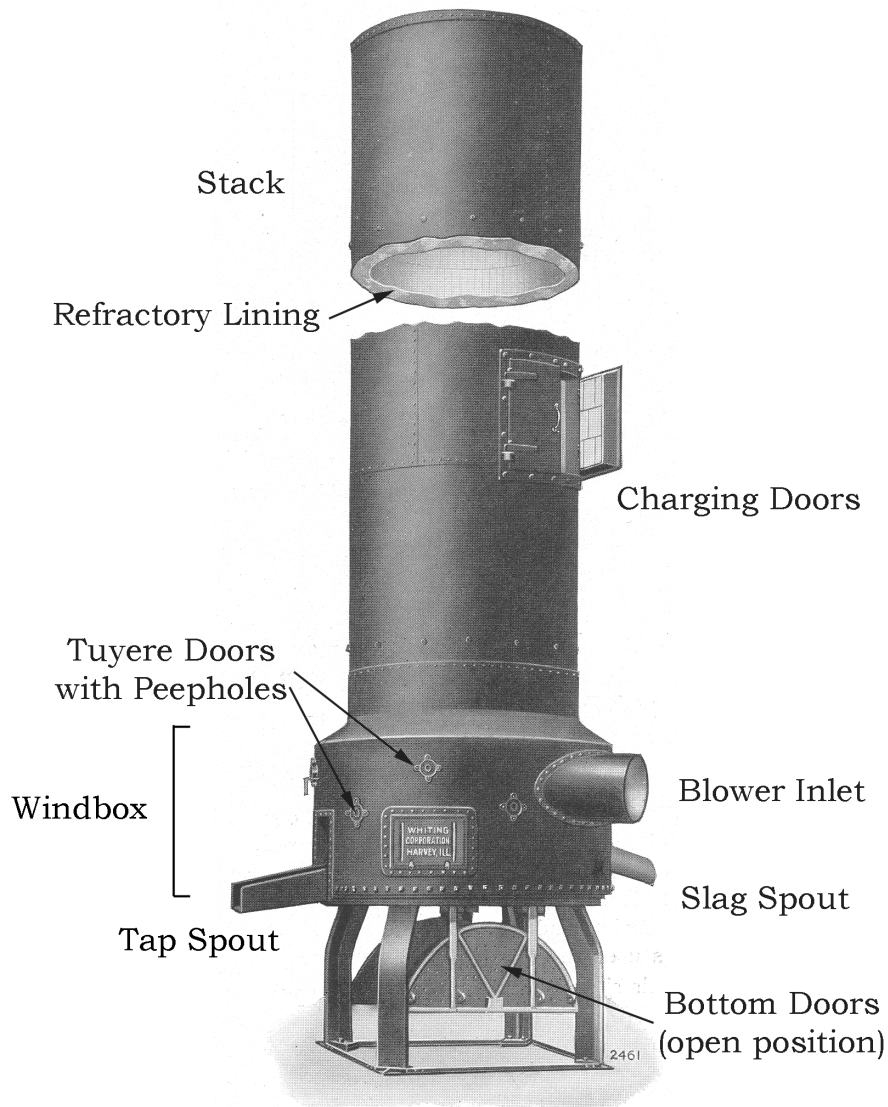

Illustration 1. Components of a Whiting Standard Cupola. Drawing is reproduced from catalog of the S. Obermeyer Co.⁴ and component names are from literature of Whiting Equipment Canada, Inc.⁵

C. OPERATION OF THE CUPOLA

"Heat" is the period during which iron is being charged to the cupola, melted and tapped for pouring. During the heat the refractory lining is essential to insulate the exterior iron shell of the cupola from the high temperatures inside. If the lining is too thin, or if a heat is too long, the exterior can glow red in spots.⁶ Because the lining experiences abrasion during charging and melting, and also can be damaged by expansion and contraction during heat-up and cool-down of the cupola, it must be repaired before each heat.

The usual repair of the refractory lining involves application of daub; replacement of the fire brick is required only infrequently. Daub is a thick, very sticky paste that when dry serves as a refractory. It is made by tempering a mixture of ground fire brick, fire clay, and sharp sand.⁷ A foundry worker stands inside the cupola on a stool placed between the bottom doors and by hand

forces the daub into any gaps in the lining and applies a coating of daub over the entire cupola lining. He uses the same material to form the openings at the slag hole and tap hole, and to line the slag and tapping spouts. (At the Williamsport Foundry these steps are completed the day before each heat.)

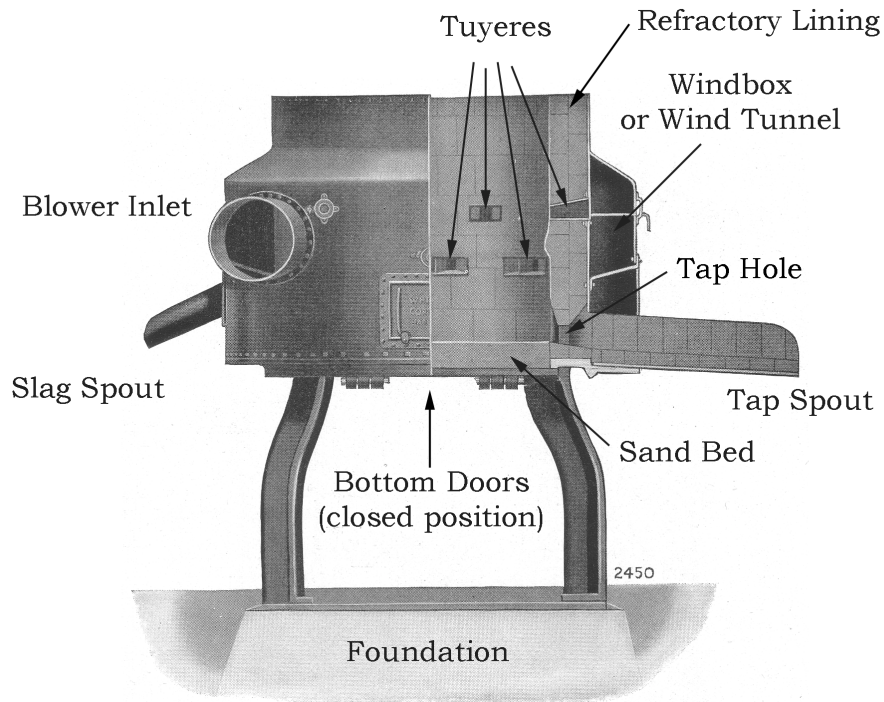

Illustration 2. Details of components at the base of a Whiting Standard Cupola.

The bottom doors are propped shut with a length of iron pipe, the lower end of which rests on a steel or iron plate. Enough sand to create a 2-inch layer is dumped in through the charging doors, and a ladder is lowered into the cupola so a man can climb down to compact the sand and slope its top surface toward the tap hole. (The sand bed can be seen in the cutaway of Illustration 2.) A special "Furnace Bottom Sand"⁸ was sold for this purpose, but a mixture of half old and half new molding sand tempered as for molding also is suitable.⁹ (The Williamsport Foundry uses heap sand.) The top of the sand is about 10 inches below the tuyeres.¹⁰ In a separate step the "breast" is formed at the tap hole; this is left open until molten iron reaches the sand layer at bottom of the cupola (see text below).

The cupola now is ready for the fire to be laid. *"An old but common method is the use of small kindling wood so that it will burn through readily and make a uniform fire for the coke bed."*¹¹ Coke is preferred as the fuel for the cupola because it is nearly pure carbon and therefore doesn't give off impurities that might affect the properties of the iron (and create odors). Charging is done through the charging doors. The diameters of the pieces of coke should be between 1/10 to 1/12 the cupola diameter¹² to ensure dense and uniform packing in the cupola and to allow channels for the blast air to flow up through the bed and for the iron and slag to run down. (At the Williamsport Foundry, newspaper and cut-up wooden shipping palettes are placed in the cupola, then coke is added; this is done shortly before the fire is to be lit.)

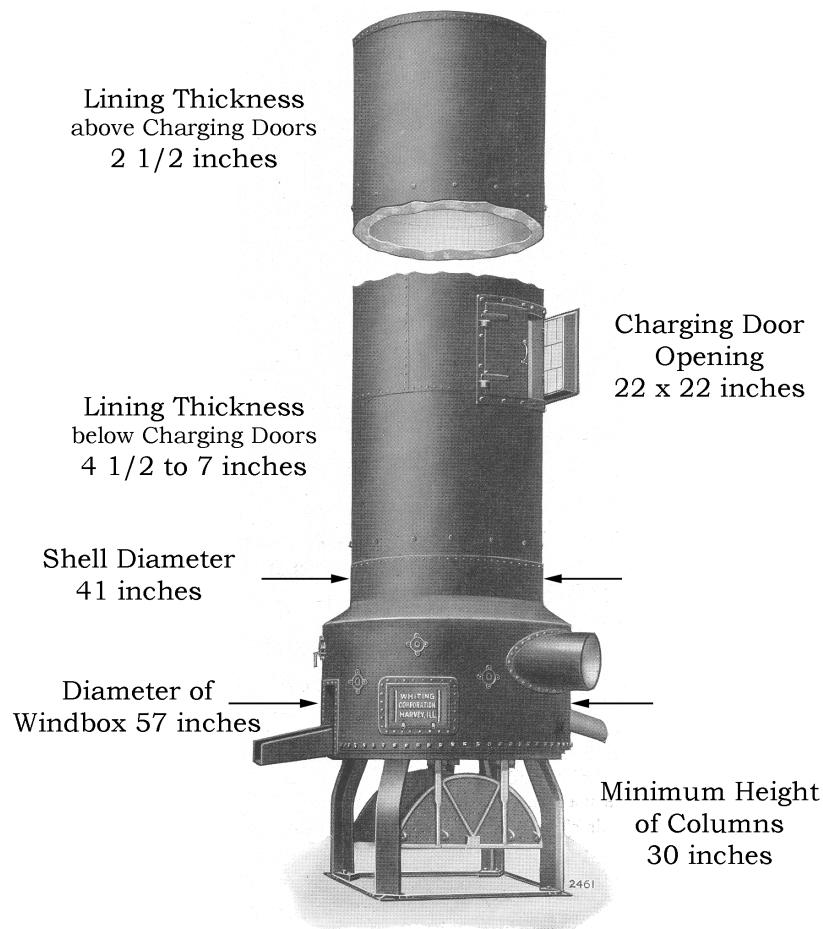

Illustration 3. Dimensions of Whiting 2 1/2 Cupola. Drawing and dimensions from catalog of the S. Obermeyer Co.¹³ The top of the windbox is about 6 feet above the foundry floor, the bottoms of the charging doors are about 15 feet above the floor and about 3 feet above the charging platform, and the overall height of the cupola is about 35 feet.¹⁴

Whiting Specifications for the No. 2 1/2 Cupola¹⁵

Refractory Lining: 7 inches minimum below charging doors.

Melting Capacity: 1 3/4 to 2 1/4 tons per hour. An earlier Obermeyer Co. catalog lists capacity as 1 to 2 tons per hour.¹⁶

Bed Coke Height above Tuyeres: 36 to 42 inches.

Charge Sizes: 45 lbs. coke, 270 to 360 lbs. iron (iron/coke ratios by weight of 6/1 to 8/1) and 9 lbs. limestone.

Airflow through Tuyeres: 1290 CFM (cu. ft. per minute)

The fire is lit about 45 minutes to an hour before the cupola is to be tapped and pouring is to begin. The charging doors are closed, the tuyere doors are opened (the blower isn't needed at this point), and the fire is lit. When the wood has burnt out and the coke bed is afire, additional coke is added to bring the bed up to its normal height, which is about 30 to 60 inches above the tuyeres.¹⁷

"A good way to determine the proper amount of coke on the bed is to check the length of time from turning on blast until iron starts to melt. If the bed is near the right height, iron should pass the tuyeres in four to five minutes, and show at the tap hole in six to eight minutes, providing proper volume of air is being supplied. If it takes longer for iron to show at the tap hole, then coke bed is too high and fuel is being wasted. If iron shows at the tap hole in less than six minutes, coke bed is too low."¹⁸

At this point the cupola is ready for the iron to be charged. The tuyere doors are closed, and the blower is started—"but not too strong at first."¹⁹ Next a layer of iron is added, then flux and more coke. As with coke, the size of the iron pieces is important. They should not be more than one-third the inner diameter of the cupola.²⁰ The flux helps liquefy impurities so they can be drained away in the slag. Limestone is the most common material used. It can be crushed to small pieces, and spread uniformly over the charge.²¹ Alternatively, fluorspar is effective in removing sulfur and phosphorous from the iron.²² Typically, coke to iron ratios by weight are in the range 1:6 to 1:12.²³ Given the relative densities of coke and iron²⁴ this range is equivalent to about 3:1 to 3:2 by volume. Additional charges of iron, flux, and coke follow until the cupola is filled up to the charging doors.

"It is good practice to fill the cupola to the charging door and keep it full for the duration of the heat. In this way a good portion of the heat in the ascending gases is imparted to the cold material as it travels down to the melting zone."²⁵

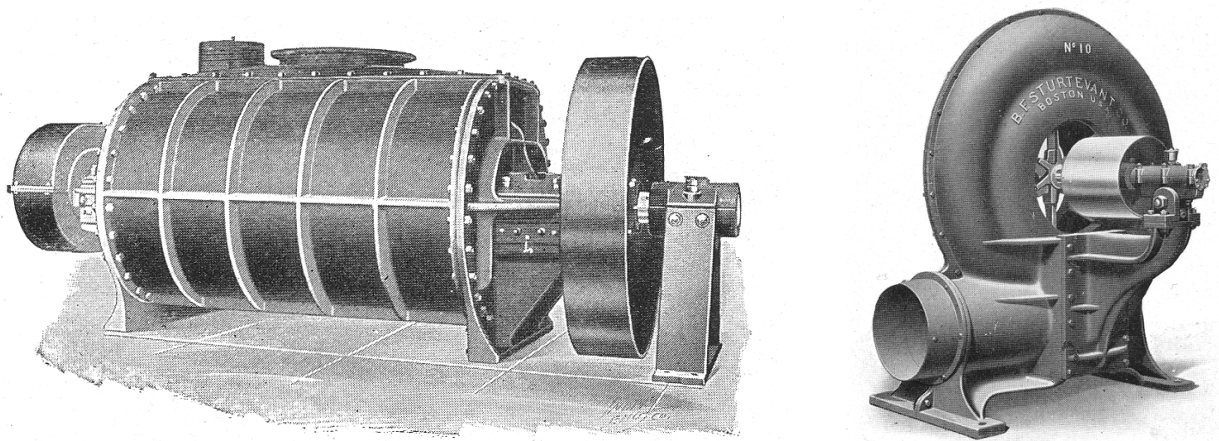

Illustration 4. Two styles of blowers used to provide blast to a cupola. A "positive pressure blower"²⁶ is at left, and a "pressure blower"²⁷ is at right.

The iron charged to the cupola is a combination of "pig iron" and "remelt." Scrap iron (from outside the foundry) also may be included. Because of differences in the amounts of minor chemical elements, the origin of the pig iron is important to the properties of the castings produced. The selection of the iron is a complex subject that deserves an article of its own. As an illustration, the following is excerpted from a letter to M. H. Cowell of Hardware & Woodenware Mfg. Co. (receivers of the "Toy Trust") from C. B. Frisbie, manager of J & E. Stevens. Cowell had suggested that a cheaper pig iron be used at Stevens and Frisbie responded:

"You will remember that our remelt of sprue is about sixty per cent, which requires a good iron or mixture to take care of it and give us soft, tough and strong castings we need, with little breakage in tumbling, drilling, tapping and finishing our work—which breakage is now very light with the iron we are using. Our castings are the lightest and remelt the largest of any one of the foundry plants [presumably meaning any of the plants in the Toy Trust].and I would not recommend a change for the difference in the prices." ²⁸

We need to digress for a moment to discuss the blower. The blower is sized to provide the proper volume of air for a particular cupola. The proper volume of blast air is very important since too little air will lead to incomplete combustion, which represents wasted energy, and generation of carbon monoxide, which is toxic. Too much air also can waste fuel and cause oxidation of the iron, which results in inferior castings.

"The quantity of blast required to melt a ton of iron varies with the coke ratio... The old figure of 30,000 cu. ft. of blast per ton of iron melted is approximately correct for melting ratio of 1:10 in the charges, but in a larger modern furnace, with good coke, and not too much of it, 24,000 cu. ft. per ton of iron is the usual figure, and it may be even lower. For each 1,000 cu. ft. of blast per minute...from 2 to 2 1/2 tons will be melted per hour, depending on the coke ratio." ²⁹

Two styles of blowers for use with cupolas are described in the Woodison catalog from about 1912 or later and the Obermayer catalog from about 1924. Both styles could be driven from a line shaft of the sort available to supply power in an old foundry.³⁰ Examples are shown in Illustration 4. One is the "Positive Pressure Blower"³¹ or "Type S-F Foundry Blower"³² that resembles a cylinder resting on its side. Depending on the blower size and the size of the cupola to which it is connected, this blower operated at speeds of 130 to 300 RPM. The other style is the "Pressure Blower,"^{33,34} which again resembles a recumbent cylinder, but in this case the diameter is greater than the width. This style operated at speeds about 10 times greater than those for the "Positive Pressure Blower." (The Williamsport Foundry has two "Pressure Blowers;" one is a back-up.)

When sparks appear from the tap hole, signaling that the first iron has reached the tap hole, a sand core plug made for this purpose is forced into the breast. Not much later slag will begin to flow out the slag hole. When iron also comes out (you can tell by the sparkler-like fireworks) the molten iron in the bottom of the cupola is several inches deep. (At this point the cupola charge actually is floating on the molten iron.) Then it's time to tap the cupola by using the tapping chisel to remove the plug from the breast so that iron can flow down the tapping spout to the ladle.

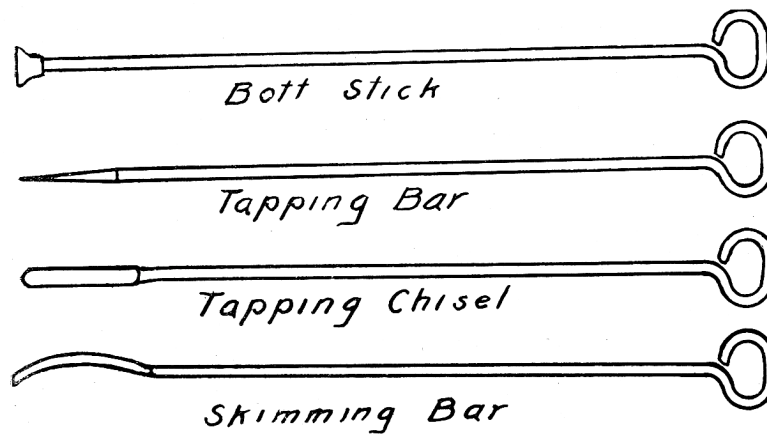

Illustration 5. Tools used by the cupola tender.³⁵

When the ladle is full, the tap hole is plugged with the "bott," which is a piece of clay hardened onto the end of a bott stick that can be removed and reinserted each time the cupola subsequently is tapped.

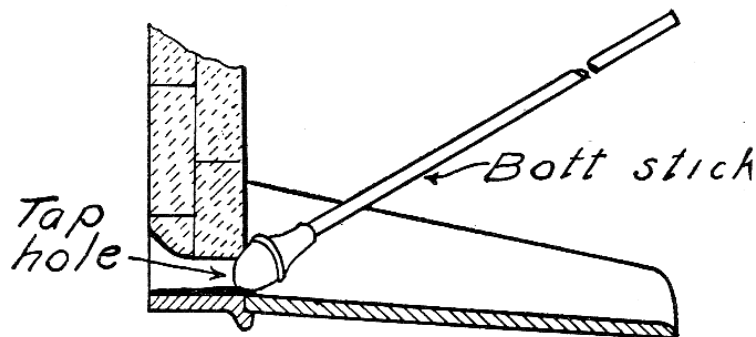

Illustration 6. Tap hole of the cupola plugged with the bott.³⁶ Notice that the bott stick is angled down toward the tap hole.

As molten iron is tapped from the cupola, additional charges of iron and coke are added to the cupola. (As noted earlier, the objective is to keep the cupola full up to the charging doors.) In the meantime iron is being poured into the molds. The work must be arranged so that the rate at which iron is poured is at least as great as the rate at which iron is being melted in the cupola.

Charging and tapping of the cupola continues until sufficient iron has been collected to pour all of the molds on the foundry floor. Then the cupola is prepared to be dumped (see later section).

D. POURING THE IRON

The iron is collected from the cupola and poured into the molds using ladles of various styles and sizes. The ladle that receives the iron from the cupola can be called the "bull ladle," but some foundrymen use this term to refer to a particular style of ladle. In any case, the largest ladles are geared ladles that are lifted by a crane and controlled (tipped) with a hand wheel. These are used to pour large castings and/or to move iron from the cupola to smaller ladles for pouring.

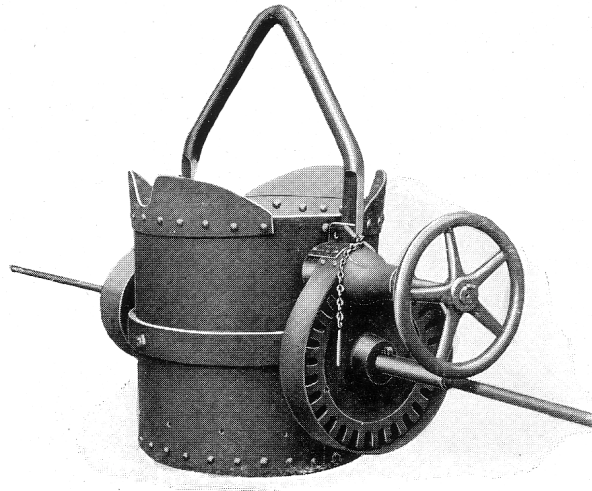

Illustration 7. Geared ladle carried by overhead hoist or crane. Capacities range from 500 to 30,000 lbs. of molten iron.³⁷

A shanked ladle is a two-man ladle used to pour iron or to transfer it to one-man hand ladles. Each shank can have one end, two ends, or two ends with swivel. At least one shank is double-ended and is used to tip the ladle. For capacities of up to 150 lbs. the shanks also were used to lift the ladle; a bale was attached to larger ladles for lifting with a crane or hoist.

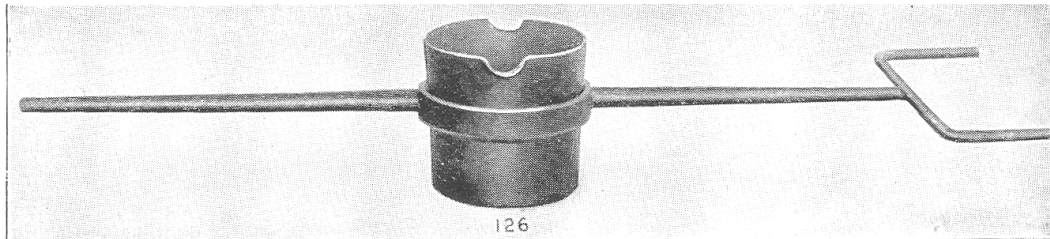

Illustration 8. A shanked ladle with "single end shank." Capacities range from 80 to 1,000 lbs.³⁸

The smallest ladles are the one-man ladles.

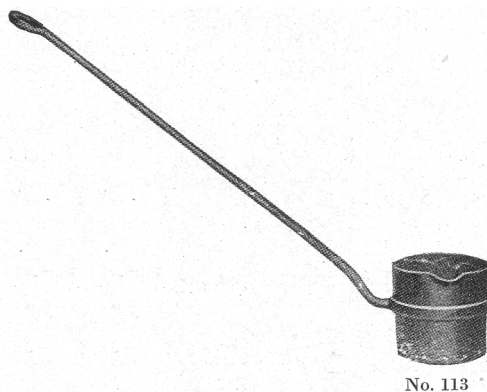

Illustration 9. One man hand ladle with capacities of 30 to 70 lbs. of molten iron.³⁹

Ladles of all sizes were made of either steel or cast iron. To help resist the heat of the molten iron, the smaller ladles are given a clay wash, and the larger ladles are lined with fire brick and a

layer of daub. In preparation for a heat, remnants of iron remaining in the ladles from earlier pours are chiseled out. Then wood fires are set in the ladles to ensure that they are completely dry and to pre-heat them so they don't excessively cool the molten iron.

E. DUMPING THE CUPOLA

When sufficient iron has been tapped to complete the pours, the blower is turned off. Iron remaining in the cupola is poured into depressions in the foundry floor or in piles of molding sand. When it has cooled this iron is collected and is re-melted during a subsequent heat.

Then the pipe supporting the bottom doors is knocked away. The doors swing open and the contents of the cupola are dumped onto the floor under the cupola. With care taken to not wet the cupola surfaces, water is sprayed onto the burning coke to extinguish it so it can be reused.

F. SHAKING OUT THE MOLDS

The molds for smaller castings are allowed to cool slowly over a period of several hours. This slow cooling is important if the castings are to be machinable. However, with larger castings shake-out might begin even while other molds still are being poured.

Each casting consisted of one or more useful parts, plus the gates and sprue. In the case of smaller castings, the parts are immediately broken from the sprue and each kind of part placed in a separate barrel, with the gates and sprue put into a separate barrel to be re-melted.

After the molds are shaken-out, the flasks and bottom boards are stacked and the sand is gathered and prepared to be used again for molding.

Glossary of Foundry Terms Part 2*

Bott: A hemispherical lump of clay hardened onto the end of the bott stick and used to plug the breast of the cupola.

Coke: The highly porous carbonaceous residue created by baking low-ash, low-sulfur bituminous coal in an airless oven at about 1,800 degrees Fahrenheit. Coke may be burned with little or no smoke.

Daub: The material used to coat the fire brick lining of the cupola and to line the ladles. Whiting recommends a mixture of 1/4 ground fire brick, 1/4 fire clay, and 1/2 sharp sand that is mixed and tempered the day before it is applied.⁴⁰

Fire Brick: Brick formed of fire clay or refractory siliceous materials and used as a refractory lining for cupolas and larger ladles. Also, **Fire Clay:** clays such as Kaolin (the mineral kaolinite) that are refractory and can withstand thermal expansion and contraction.⁴¹

Flux: A material added to the cupola charge to help liquefy impurities. The most common flux is limestone. Fluorspar or fluorite also is used as a flux; it is a naturally occurring mineral consisting mostly of calcium fluoride.

Heat: The time when the cupola is alight and melting iron.

Peep Hole: A mica window in the tuyere door through which the cupola operator can see into the cupola.

Pig Iron: Iron newly smelted from iron ore.

Refractory: A material capable of withstanding very high temperatures and reactive conditions. Also, **Refractory Lining:** a refractory used to line and insulate the cupola and ladles.

Remelt: Also called **Returns**. The sprues, substandard castings, and other iron from a previous pour. Basically remelt is iron that is recycled within the foundry.

Slag: The molten impurities that are separated from the iron by being drained from the slag hole. Slag hardens to a glassy solid as it cools. Also, **Slag Hole:** the opening in the cupola through which the slag drains.

Tap Hole: The opening at the base of the cupola through which molten iron flows out. Also, **Breast:** the opening at the tap hole that can be sealed and resealed with the bott.

Tuyeres: Openings at the base of the cupola that allow air to flow in from the windbox. Also, **Tuyere Door:** a cover over the opening in the firebox that is opposite each tuyere. The tuyere door has a peep hole, a mica-covered opening through which the interior of the cupola can be seen.

Windbox: Also called the **Wind Tunnel**. An air-tight, concentric cylinder of boilerplate around the bottom section of the cupola that distributes air from the blower to the tuyeres.

* For Part 1 see "Patterns and the Molding of Cast Iron Banks."
p. 10

Appendix

Melting and Pouring Iron at the Williamsport Foundry

The photos in this appendix show the melting and pouring of iron at the Williamsport Foundry, 164 Maynard St., in Williamsport, Pennsylvania. They were taken in June 2005. At the end of the Appendix is a brief history of the foundry.



Photo 1. Office and pattern shop at the Williamsport Foundry. (Building in background is for storage.)

The foundry is owned by Jeep, Bud, and Frank Doebler. It has about twenty-five employees and pours 20 to 30 tons of iron each week. Castings produced are as small as a few ounces and as large as 3 or 4 tons.

Operations are on a six-day schedule, with two cycles of three days each:

On Monday (and Thursday) molding begins and continues Tuesday (Friday) morning. The cupola lining is repaired, and the cupola charges are laid out on the charging platform.

About 11 a.m. on Tuesday (Friday) the cupola is charged and lit. Pouring of iron begins about 12:30, followed by shake out and general clean-up at about 3 p.m.

On Wednesday (Saturday) shake-out is completed and everything is readied for a new round of molding.

The Whiting 2 1/2 cupola has been used since 1930, when it was purchased at the Foundrymen's Convention in Cleveland. Wilson Doebler, Sr. relates that the refractory lining originally consisted of a single layer of fire brick, but later, in order to allow longer heats. a second layer was added.



Photo 2. Piles of coke and pig iron. The coke is derived from bituminous coal mined in Kentucky, and the pig iron comes from Brazil.



Photo 3. Scrap iron that comes from a local dealer. In the right background is storage for the daub used to repair the cupola's refractory lining.



Photo 4. Views up and down the rails for cable car used to transport materials from ground level up to the cupola charging platform.



Photo 5. Newspaper, wood, coke, and iron to be charged through the charging doors in background. At the upper right can be seen part of an afterburner that combusts any carbon monoxide in the stack gases.

Composition of the Charges

When the coke is on fire, additional coke is added to bring the cupola up to about one-third full. Then limestone, 950 lbs. of iron, and 100 lbs. of coke are added. Two additional layers of iron and coke bring the charge up to the bottom of the charging doors.

Each charge of iron consists of:

300 lbs. pig iron (newly smelted iron in 20 lbs. blocks called "pigs.")

300 lbs. scrap iron (from scrap dealer)

300 lbs. "returns" (iron recycled within the foundry consisting of the sprues, runners, and risers from castings and extra iron from earlier heats.)

50 lbs. steel plate (also from scrap dealer)

So, each casting produced consists of more than half recycled scrap iron.

The scrap iron is specified to have no pipe and or radiators, because when the latter were cast high phosphorous levels were necessary to enhance flow of the molten iron. For general use phosphorous is objectionable because it makes castings difficult to machine. Scrap consisting of "southern iron" also is avoided.

When special properties are required of the cast parts, additives are mixed with the molten iron in the ladle. Silicon metal is added to reduce the "chill" (improved machinability) of the castings. Other alloying materials contain nickel, molybdenum or chromium.



Photo 6. Bud Doebler pointing to record of pours during previous heat chalked onto wall near the cupola.



Photo 7. The charging doors on the cupola.



Photo 8. Looking down into the cupola through the charging doors. Notice the layer of daub. (The chain is supporting a wooden ladder used to enter the cupola to level sand on the bottom doors.)



Photo 9. Slag hole and spout of the cupola. Note the fresh coating of daub.



Photo 10. Bottom doors of cupola propped shut with a length of iron pipe (see white arrow).



Photo 11. One of the tuyere doors.



Photo 12. The cupola ready to be tapped and the ladle in position to receive the iron. On the opposite side of the cupola a stream of slag is pouring out the slag hole, and the sparkler effect indicates that iron also is reaching the height of the slag hole.



Photo 13. Slag flowing from the cupola's slag hole onto the foundry floor.



Photo 14. The cupola's tap hole open and iron flowing to the large geared ladle. This particular ladle has a capacity of 1,000 lbs.



Photo 15. Iron being transferred to a smaller ladle for pouring.



Photo 16. A pour directly from the large geared ladle. Depending on iron temperature and size of the molds, the iron remains hot enough to pour for about 20 minutes.



Photo 17. A "double pour" being made simultaneously from two ladles. Frank Doebler is at the far right.



Photo 18. Excess iron being poured from the cupola into a pit in the foundry floor.



Photo 19. The scene a few seconds after the cupola had been dumped. Water is being sprayed onto the coke to quench the fire.



Photo 20. Shake-out beginning and bottom boards being gathered. The fumes are steam.

Brief History of the Williamsport Foundry

The Williamsport Foundry was established in 1916 by William Ertel and Walter E. Ertel, Sr. and has been in the same family since. It first was located in a converted chicken coop at 124 West St., which is about six blocks north and east of the current location. A new building was constructed in 1919, and in 1938 the Ertel brothers moved to 164 Maynard St. where they took over operation of the foundry there.

In 1956 Walter Ertel, Sr., his son Walter (Sonny), Jr. and his sons-in-law Carl Seitzer and Wilson Doebler, Sr. purchased the foundry. Carl was married to Walter's daughter Annamae, and Wilson to daughter Emily. Wilson had been a wood worker involved in remodeling the Maynard St. foundry when the Ertels took it over in 1938 and subsequently worked in different areas of the foundry, eventually specializing in the pattern shop. Later Wilson's sons Wilson, Jr. (Jeep), Walter (Bud), and Frank joined the foundry. Carl Seitzer died in 1972, and Sonny retired in 1992 and sold his interest to Wilson and his sons Jeep, Bud, and Frank. They took over when Wilson retired in January, 2005 after sixty-five years as a foundryman. (Son Bud jokes that he caught his dad napping and had to let him go.)

Originally the Williamsport Foundry poured only brass and bronze. They expanded into iron in 1930. As recently as five years ago brass, bronze, and aluminum were poured almost daily. Because safety and environmental regulations have made it very difficult to work with these metals, today the Foundry pours iron almost exclusively. They pride themselves on being able to locate patterns placed into storage years ago, and in pouring castings that others have found difficult to produce.

The Williamsport Foundry is the last foundry in Williamsport. In its heyday, Williamsport was considered the "lumbering capital of the world" and had more millionaires per capita than anywhere in America. The need for lumbering equipment and the proximity of ample supplies of coal and iron attracted more than twenty foundries, including Lycoming Motors (engine blocks), Spencer Heater (boilers and radiators), and Darlene Valve (fire hydrants and valves).

Revised October 25, 2005.

Acknowledgement: My understanding of cupola structure and operations is largely based on what I have been taught by Bud and Frank Doebler. I am extremely grateful to them for welcoming me to their foundry and for patiently answering my many questions. The copy of the letter from Frisbie to Colwell was provided by Robert Saylor. Bob's scholarly research and the insight it provides is greatly appreciated. And, I thank Bill Jones for proofing the finished article. He pointed out gaps in my descriptions and put in several missing commas.

Please direct comments to Fritz Kokesh at fritz@toybanks.info or 2326 NE 12th Ave., Portland, Oregon 97212.

Copyright © 2005 Fritz Kokesh, Portland, Oregon; all rights reserved. This paper may not be reproduced in whole or in part without written permission. For copies contact the author or go to www.toybanks.info.

References

¹ Fritz Kokesh, "Patterns and the Molding of Cast Iron Banks, Seminar by Bill Robison," *Penny Bank Post*, April 2003, p.5.

² Boilerplate thicknesses typical for a cupola the size of a Whiting 2 1/2 per The E. J. Woodison Company, "A complete Catalog of Foundry, Platers' and Polishers' Supplies and Equipment, Fire Brick and Refractory Materials," 1912 or later, p. 39.

³ Temperatures obtained by blast in heat of fire: 2493 °F with cold blast or 2793 °F with warm blast, per Woodison, p. 348.

⁴ The S. Obermayer Co., "Manufacturers, Everything You Need in Your Foundry," General Catalog No. 51, undated, 1924 or later (on p. 13 is a Dec 2, 1924 patent date), p. 227.

⁵ "Practical Hints on Cupola Operation," Whiting Equipment Canada Inc.

⁶ Wilson Doebler, Sr., June 10, 2005.

⁷ Whiting, p. 8.

⁸ Woodison, p. 28.

⁹ Whiting, p. 9.

¹⁰ Woodison, p. 39.

¹¹ It also is possible to ship the wood and use an oil or gas torch or an electric igniter to light the coke, per Whiting, p. 9.

¹² Whiting, p. 7.

¹³ Obermayer p. 231.

¹⁴ Woodison, p. 39.

¹⁵ Whiting, p. 15.

¹⁶ This is the capacity for the Whiting 2 1/2 B cupola. The model 2 1/2 A has a lining thickness of 4 1/2 inches and a melting capacity is 3 to 5 tons per hour. See Obermayer p. 231.

¹⁷ Whiting, p. 10.

¹⁸ Whiting, p. 10.

-
- ¹⁹ William A. Richards, "A Text-Book of Elementary Foundry Practice," The Macmillan Company, New York, 1912, p. 92.
- ²⁰ Whiting, p. 7.
- ²¹ Whiting, pp. 7-8.
- ²² Woodison, p. 32.
- ²³ Whiting, p. 15.
- ²⁴ Obermayer, pp. 333-334.
- ²⁵ Whiting, p. 11.
- ²⁶ Woodison, p. 43.
- ²⁷ Obermayer, p. 241.
- ²⁸ Letter of May 5, 1909 from C. B. Frisbie of the J. & E. Stevens Co. to Mr. Colwell of the Hardware & Woodenware Manufacturing Co., subject: "Pur. Order H-1046, Pig Iron."
- ²⁹ Obermayer, p. 238.
- ³⁰ Obermayer, p. 241.
- ³¹ Woodison, pp. 43-44.
- ³² Obermayer, pp. 239-240.
- ³³ Woodison, pp. 45-46.
- ³⁴ Obermayer, pp. 241-243.
- ³⁵ Richards, p. 90.
- ³⁶ Richards, p. 92.
- ³⁷ Woodison, p. 57.
- ³⁸ Woodison, p. 52.
- ³⁹ Woodison, p. 51.
- ⁴⁰ Whiting, p. 8.
- ⁴¹ Woodison, p. 28.